

IN SINK ERATOR®

555ss 3/4 Horsepower Food Waste Disposer

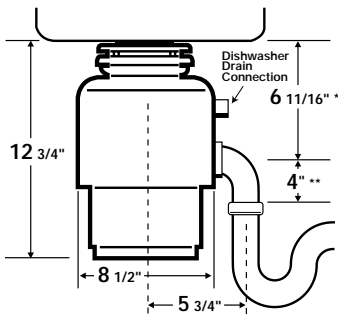

Dimensions



* Distance from bottom of sink to center line of disposer outlet.

Add 1/2" when stainless steel sinks are used.

** Length of tailpipe from center line of disposer outlet to end of tailpipe.

NOTE: Plumb waste line to prevent standing water in disposer motor housing.



IN SINK ERATOR®

Submittal Sheet

- 5 year parts and in-home service warranty*
- Fully insulated outer shell
- Stainless steel grind chamber
- Stainless steel grinding elements with two stainless steel 360° swivel lugs
- Exclusive corrosion protection shield
- One-piece stainless steel stopper
- Dishwasher drain connection
- Permanently lubricated upper and lower bearings
- Overload protector manual reset
- Exclusive cushioned anti-splash baffle
- Quick Lock™ mounting for fast, easy installation
- Exclusive self-service wrench
- Water seal

Sample Specification

Food Waste Disposer(s) shall be In-Sink-Erator Model 555ss, continuous feed, single direction, with 3/4 H.P. motor, corrosion protection shield, self-service wrench, stainless steel grinding elements with two stainless steel 360° swivel lugs. Warranty - 5 year parts and in-home service.

* The complete In-Sink-Erator warranty is included in the Care & Use Booklet, packed with each unit.

Specifications

Type of Feed	Continuous
On/Off Control	Wall Switch
Motor	Single Phase
HP	3/4
Volts	120
HZ	60
RPM	1725
Amp. (Avg. Load)	8.1
Time Rating	Intermittent
Lubrication	Permanently Lubricated Upper & Lower Bearings
Shipping Weight (Approx.)	18 lbs. 7 oz.
Unit Finish	Waterborne Grey Enamel
Overall Height	12-3/4"
Grind Chamber Capacity	50 oz.
Motor Protection	Manual reset Overload
Average Water Usage	1/4 Gallon Per Person Per Day
Average Electrical Usage	1/2 KWH Per Month
Drain Connection	1-1/2" Cushioned Slip Joint
Dishwasher Drain Connection	Yes

Job Specifications

