

# Food Waste Disposers



## Submittal Sheet

This popular model offers the following features and benefits:

- 1/2 Horsepower Heavy Duty Motor (Quiet Dura-Drive® Induction Motor)
- 1-Year *We Come To You™* In-Home Parts And Labor Service Warranty
- Rugged Galvanized Steel Construction (For Disposer Durability)
- Space-Saving Compact Design

## Specifications

Type of Feed	Continuous
On/Off Control	Wall Switch
Motor	Single Phase
HP	1/2
Volts	120
HZ	60
RPM	1725
Amp. (Avg. Load)	6.9
Time Rating	Intermittent
Lubrication	Permanently Lubricated Upper & Lower Bearings
Shipping Weight (Approx.)	14 lbs. 11 oz.
Unit Finish	Waterborne Grey Enamel
Overall Height	12-5/8"
Grind Chamber Capacity	32 oz.
Motor Protection	Manual Reset Overload
Average Water Usage	1/4 Gallon per Person Per Day
Average Electrical Usage	1/2 KWH per Month
Drain Connection	1-1/2" Cushioned Slip Joint
Dishwasher Drain Connection	Yes

## Dimensions

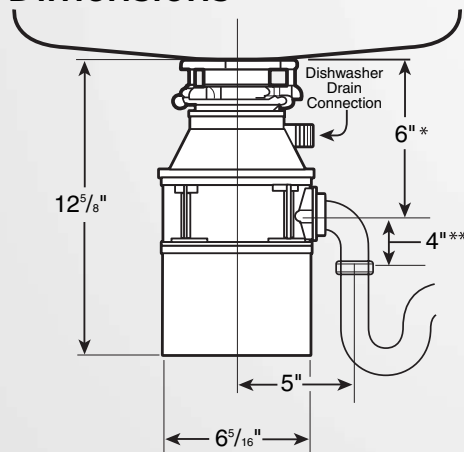

- \* Distance from bottom of sink to center line of disposer outlet. Add 1/2" when stainless steel sinks are used.  
 \*\* Length of tailpipe from center line of disposer outlet to end of tailpipe.  
 NOTE: Plumb waste line to prevent standing water in disposer motor housing.

## Sample Specification

Food Waste Disposer(s) shall be InSinkErator Badger 5, continuous feed, with 1/2 H.P. motor, galvanized steel grinding elements with two stainless steel 360° swivel lugs. Self-service wrench.

**Warranty:**  
 2- Year parts and in-home service.

\* The complete InSinkErator warranty is included in the Care & Use Booklet packed with each unit.

## Job Specifications

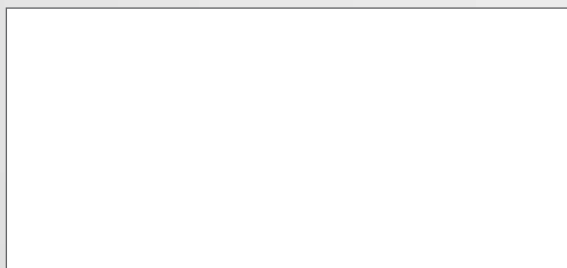

1-800-558-5700  
[www.insinkerator.com](http://www.insinkerator.com)

**EMERSON**  
 Appliance Solutions

The Emerson logo is a trademark and service mark of Emerson Electric Co.  
 InSinkErator is a division of Emerson Electric Co.